

**Instruction Sheet
for the PASCO
Model ME-8952**

Centripetal Force Accessory

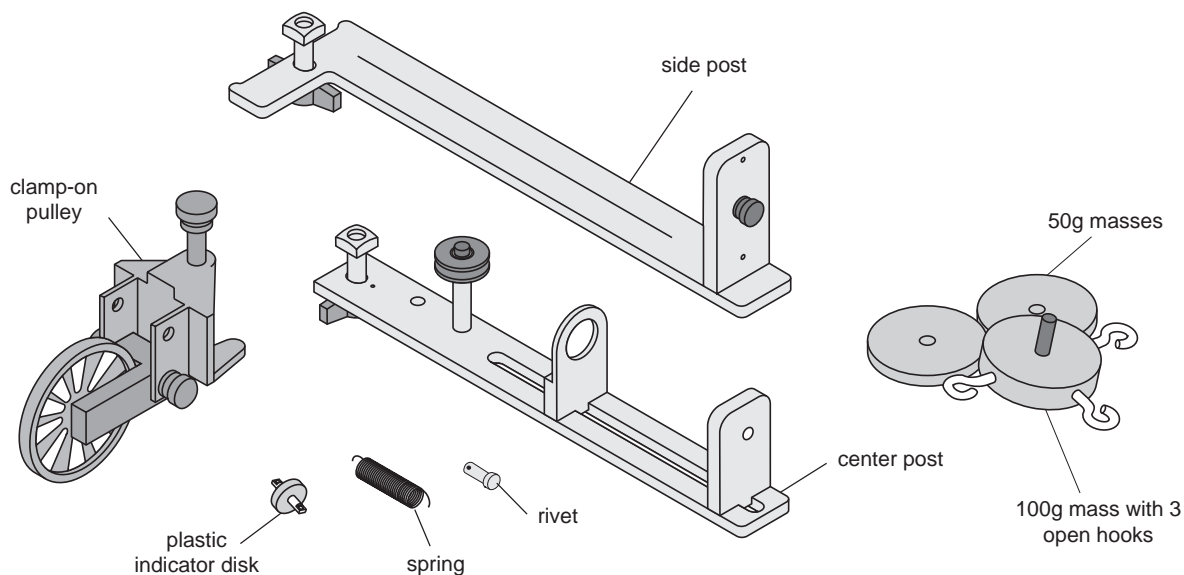

Introduction

The ME-8952 Centripetal Force Accessory is comprised of two vertical posts which can be mounted to the Rotating Platform with thumbscrews. These posts are adjustable and can be positioned virtually anywhere along the length of the platform. The radius indicator is at the center of the apparatus so it can be clearly seen while the apparatus is rotating. The PASCO Centripetal Force Accessory can be used to experiment with centripetal force and conservation of angular momentum. For the centripetal force experiments it is possible to vary the mass and radius to see the resulting change in the centripetal force. The force can also be held constant while other quantities are varied. The Centripetal Force Accessory is powered by hand and the rate of rotation can be counted manually or read by a computer. Variable hanging masses are included. This accessory requires the Rotating Platform (ME-8951) to operate.

See the Complete Rotational Manual for experiment guide.

Equipment

The ME-8952 Centripetal Force Accessory includes:

- center post that supports an indicator mechanism which consists of a small pulley, a movable spring holder, a movable indicator, a rivet, a spring, and a plastic indicator disk
- side post for hanging hooked mass
- mass (100 g) with 3 open hooks
- 2 additional 50 gram masses
- clamp-on pulley

© 1994 PASCO scientific

This instruction sheet written by: Ann and Jon Hanks and edited by: Eric Ayars

Center Post Assembly

Assemble the center post as shown in Figure 1:

- ① Drop the rivet through the hole in the top of the spring bracket. Connect one end of the spring to the hole in the end of the rivet. Connect the plastic indicator disk to the other end of the spring.
- ② Tie one end of a string (about 30 cm long) to the bottom of the plastic indicator disk and tie a loop in the other end of the string.
- ③ Insert the indicator bracket into the slot on the center post, placing it below the spring bracket. Tighten the thumb screw.
- ④ Attach the pulley in the higher of the two holes on the center bracket.
- ⑤ Insert the thumbscrew at the bottom of the center post and attach the square nut.

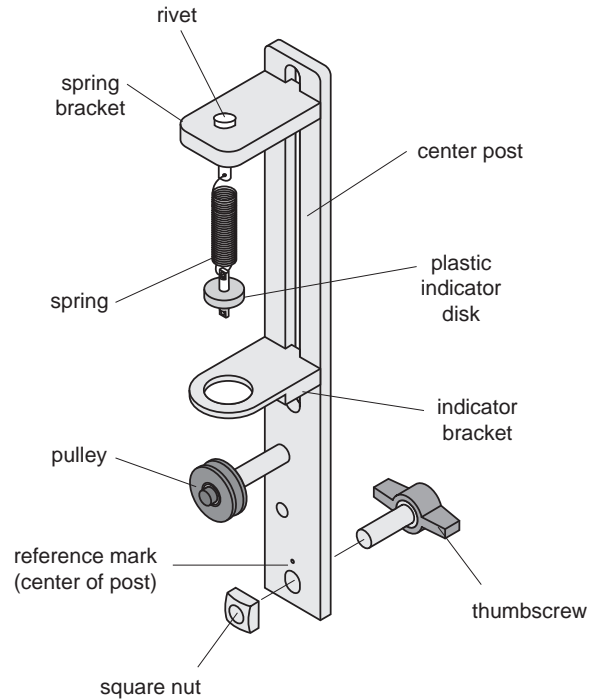

Figure 1: Center Post Assembly

Side Post Assembly

Assemble the side post as shown in Figure 2:

- ① Insert the thumb screw at the bottom of the side post and attach the square nut.
- ② Using a string about 30 cm long, tie the string around the screw head on the top of the side post. Then thread the other end of the string down through one of the holes in the top of the side post and then back up through the other hole. Do not pull the string taut.
- ③ Loosen the screw on the top of the side post and wrap the loose end of the string around the threads of the screw and tighten the screw.

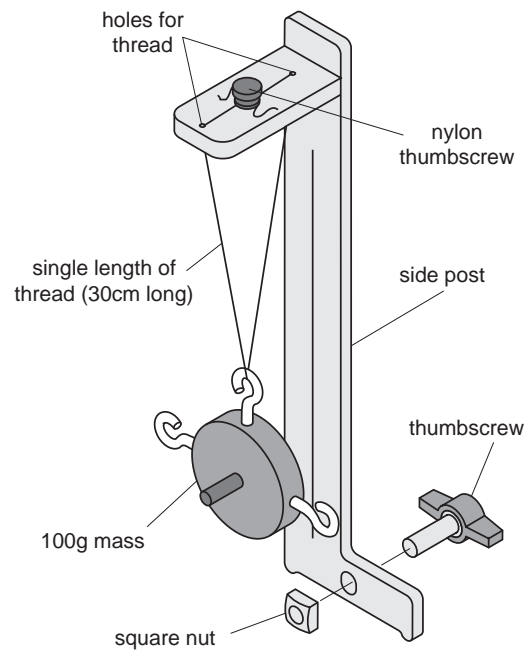

Figure 2: Side Post Assembly

Threading the Centripetal Force Accessory

- ① Mount the center post in the T-slot on the side of the track that has the rule. Align the line on the center post with the zero mark on the rule and tighten the thumb screw to secure it in place. Then mount the side post on the same side of the track. See Figure 3.
- ② Hang the object from the string on the side post and adjust the height of the object so the string coming from the center post will be level.

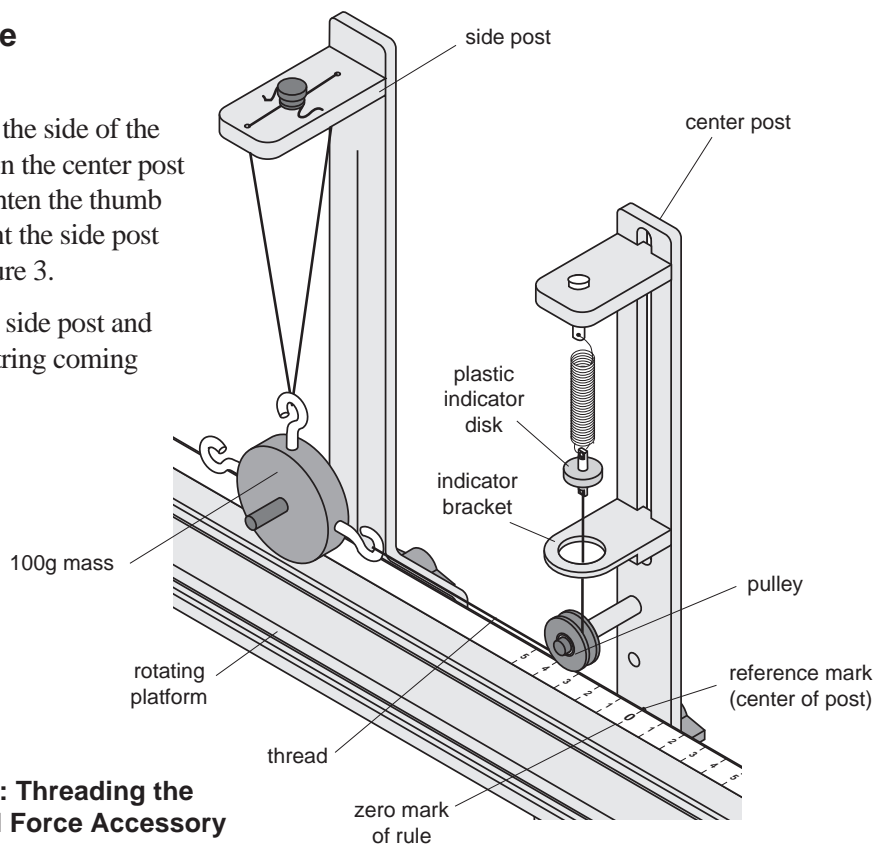

Figure 3: Threading the Centripetal Force Accessory

Limited Warranty

PASCO scientific warrants this product to be free from defects in materials and workmanship for a period of one year from the date of shipment to the customer. PASCO will repair or replace, at its option, any part of the product which is deemed to be defective in material or workmanship. This warranty does not cover damage to the product caused by abuse or improper use. Determination of whether a product failure is the result of a manufacturing defect or improper use by the customer shall be made solely by PASCO scientific. Responsibility for the return of equipment for warranty repair belongs to the customer. Equipment must be properly packed to prevent damage and shipped postage or freight prepaid. (Damage caused by improper packing of the equipment for return shipment will not be covered by the warranty.) Shipping costs for returning the equipment, after repair, will be paid by PASCO scientific.

Equipment Return

Should this product have to be returned to PASCO scientific, for whatever reason, notify PASCO scientific by letter or telephone BEFORE returning the product. Upon notification, the return authorization and shipping instructions will be promptly issued.

► **NOTE: NO EQUIPMENT WILL BE ACCEPTED FOR RETURN WITHOUT AN AUTHORIZATION.**

When returning equipment for repair, the unit must be packed properly. Carriers will not accept responsibility for damage caused by improper packing. To be certain the unit will not be damaged in shipment, observe the following rules:

- ① The carton must be strong enough for the item shipped.
- ② Make certain there is at least two inches of packing material between any point on the apparatus and the inside walls of the carton.
- ③ Make certain that packing material cannot shift in the box, or become compressed, thus letting the instrument come in contact with the edge of the box.

Technical Support

Feed-Back

If you have any comments about this product or this manual please let us know. If you have any suggestions on alternate experiments or find a problem in the manual please tell us. PASCO appreciates any customer feedback. Your input helps us evaluate and improve our product.

To Reach PASCO

For Technical Support call us at 1-800-772-8700 (toll-free within the U.S.) or (916) 786-3800.

Internet: techsupp@PASCO.com

Contacting Technical Support

Before you call the PASCO Technical Support staff it would be helpful to prepare the following information:

- If your problem is computer/software related, note:
Title and Revision Date of software.
Type of Computer (Make, Model, Speed).
Type of external Cables/Peripherals.
- If your problem is with the PASCO apparatus, note:
Title and Model number (usually listed on the label).
Approximate age of apparatus.
A detailed description of the problem/sequence of events. (In case you can't call PASCO right away, you won't lose valuable data.)
If possible, have the apparatus within reach when calling. This makes descriptions of individual parts much easier.
- If your problem relates to the instruction manual, note:
Part number and Revision (listed by month and year on the front cover).
Have the manual at hand to discuss your questions.