

**Instruction Manual for
the PASCO scientific
Model SF-9216**

012-02141H
1/96

Variable Output Air Supply

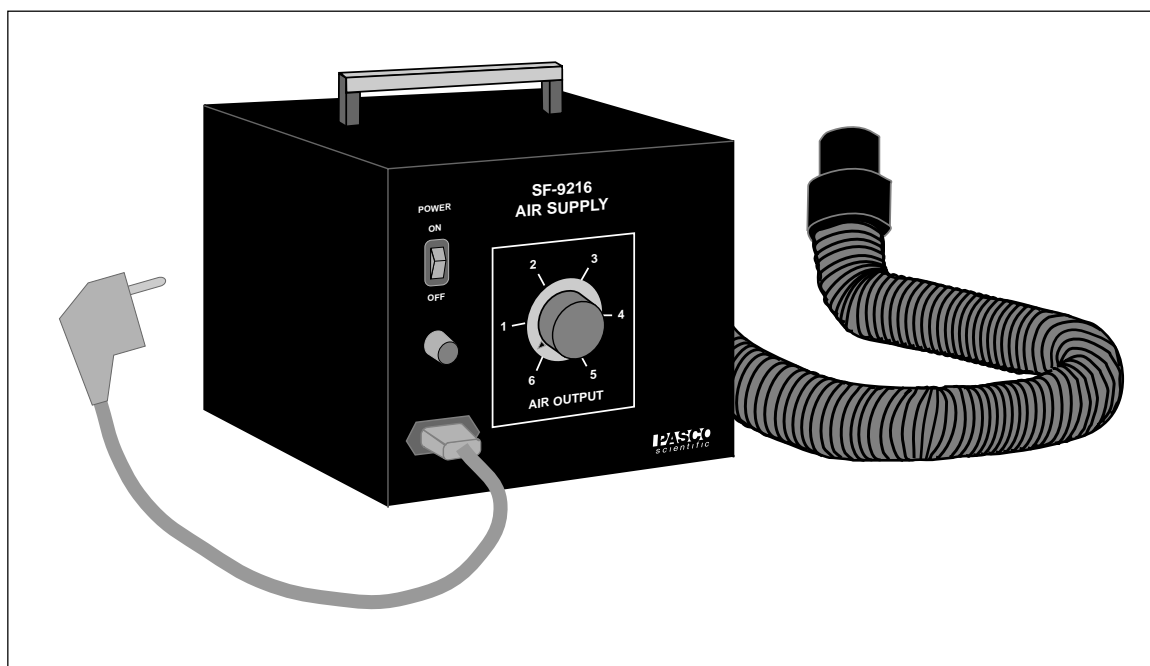

© 1991 PASCO scientific

\$5.00



The lightning flash with arrowhead, within an equilateral triangle, is intended to alert the user of the presence of uninsulated “dangerous voltage” within the product’s enclosure that may be of sufficient magnitude to constitute a risk of electric shock to persons.



CAUTION:
TO PREVENT THE RISK OF ELECTRIC SHOCK, DO NOT REMOVE BACK COVER. NO USER SERVICEABLE PARTS INSIDE. REFER SERVICING TO QUALIFIED SERVICE PERSONNEL.



The exclamation point within an equilateral triangle is intended to alert the user of the presence of important operating and maintenance (servicing) instructions in the literature accompanying the appliance.

Table of Contents

Section	Page
Copyright, Warranty, and Equipment Return	ii
Introduction	1
Operation	1
Operating Two Air Tracks	2
PCB Schematic	3
PCB Layout	4

Copyright, Warranty and Equipment Return

Please—Feel free to duplicate this manual subject to the copyright restrictions below.

Copyright Notice

The PASCO scientific Model SF-9216 Variable Output Air Supply manual is copyrighted and all rights reserved. However, permission is granted to non-profit educational institutions for reproduction of any part of this manual providing the reproductions are used only for their laboratories and are not sold for profit. Reproduction under any other circumstances, without the written consent of PASCO scientific, is prohibited.

Limited Warranty

PASCO scientific warrants this product to be free from defects in materials and workmanship for a period of one year from the date of shipment to the customer. PASCO will repair or replace, at its option, any part of the product which is deemed to be defective in material or workmanship. This warranty does not cover damage to the product caused by abuse or improper use. Determination of whether a product failure is the result of a manufacturing defect or improper use by the customer shall be made solely by PASCO scientific. Responsibility for the return of equipment for warranty repair belongs to the customer. Equipment must be properly packed to prevent damage and shipped postage or freight prepaid. (Damage caused by improper packing of the equipment for return shipment will not be covered by the warranty.) Shipping costs for returning the equipment, after repair, will be paid by PASCO scientific.

Credits

This manual edited by: Dave Griffith

Equipment Return

Should the product have to be returned to PASCO scientific for any reason, notify PASCO scientific by letter, phone, or fax BEFORE returning the product. Upon notification, the return authorization and shipping instructions will be promptly issued.

► **NOTE:** NO EQUIPMENT WILL BE ACCEPTED FOR RETURN WITHOUT AN AUTHORIZATION FROM PASCO.

When returning equipment for repair, the units must be packed properly. Carriers will not accept responsibility for damage caused by improper packing. To be certain the unit will not be damaged in shipment, observe the following rules:

- ① The packing carton must be strong enough for the item shipped.
- ② Make certain there are at least two inches of packing material between any point on the apparatus and the inside walls of the carton.
- ③ Make certain that the packing material cannot shift in the box or become compressed, allowing the instrument come in contact with the packing carton.

Address: PASCO scientific
10101 Foothills Blvd.
Roseville, CA 95747-7100

Phone: (916) 786-3800
FAX: (916) 786-3292
email: techsupp@pasco.com
web: www.pasco.com

Introduction

The PASCO Air Supply is exceptionally quiet, and its variable output lets you precisely match the air flow to the experiment. (Too much air causes turbulence, resulting in glider drift.)

A 2.0 meter hose is included. By adding the SF-9217 T-Adapter and Hose described below, the Air Supply can be used to operate two PASCO SF-9214 Air Tracks at the same time.

► **NOTE:** This Air Supply is for use with the SF-9214 Precision Air Track. If used with a different track, the total area of the air flow holes must be $\geq 2.6 \text{ cm}^2$ (0.4 in^2).

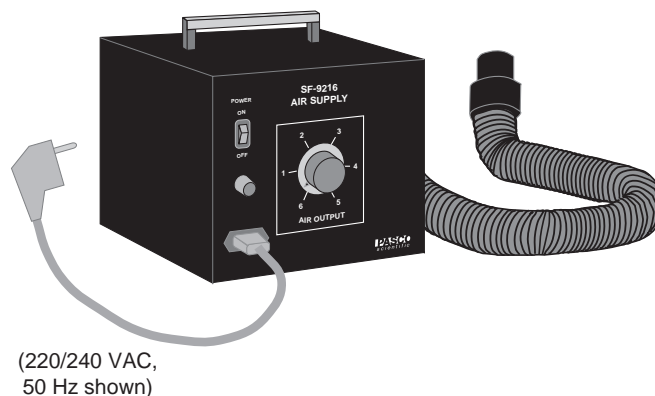

Figure 1 SF-9216 Air Supply

Operation

Setting Up the Air Supply

Insert the short, thick-wall coupling on one end of the hose into the hole in rear of the air supply. The other end of the hose, with the longer, thin-wall coupling, fits into the hole of the PASCO 2 meter Precision Air Track (square cross section, aluminum color).

Connect the air supply to a wall socket (115 VAC, 60 Hz or 220/240 VAC, 50 Hz). The respective line voltages are marked on the rear panel. Turn the unit on with the power switch.

Leave at least three inches of clearance around all sides of the blower for air intake and cooling.

If you wish to connect the SF-9216 Air Supply to the Daedalon 1.5 m Air Track (triangular cross section, black color) it will be necessary to wrap one or two layers of electrician's tape around the air coupling on the track. The hose from the Air Supply should now fit snugly over the coupling.

Adjusting the Air Supply

The air flow from the Air Supply is easily adjusted by the knob on the front panel. Once the air track is set up and operating, adjust the air flow until the gliders just glide freely on the track.

If the air flow is too low, the glider will touch the track and lose energy.

A higher air flow may cause the gliders to move randomly in response to air turbulence around the surface of the track.

► **NOTE:** The apparatus is calibrated at 220 VAC, 50 Hz and must be re-calibrated for 220 VAC, 60 Hz. Please follow the instructions in the following section.

Adjusting the Motor Speed (Air Flow)

Turn the control knob fully COUNTER-clockwise. After switching on the motor, slowly turn the control knob CLOCKWISE. The motor should begin running when the pointer on the control knob is near the “2” position. If it does not, then follow this procedure:

►CAUTION: When the case is opened, there will be exposed high voltages. This unit should be serviced or adjusted only by trained technicians.

- ① Remove the four screws which attach the control panel to the main unit.
- ② On one end of the printed circuit board are two trim potentiometers designated as TR1 and TR2 (See Figure 3).

- ③ Set TR1 and TR2 to their mid position and turn the power switch to “ON”.
- ④ Set the speed control knob (P1) fully *counter*-clockwise (“1”) and turn TR1 clockwise until the motor just begins to turn smoothly.
- ⑤ Set the speed control knob fully *clockwise* (“6”) and adjust TR2 until the motor runs at maximum speed.
- ⑥ Replace the control panel.

Fuse Replacement

The fuse is a dual-element delay type. Replace with the following fuse ratings:

For the 110V version use a 5A/117V fuse.

For the 220V version use a 2.5A/250V fuse.

Operating Two Air Tracks

Operating Two Air Tracks

Two air tracks may be operated on a single Air Supply by using the optional “T” and hose, Model SF-9217. The “T” is inserted into the Air Supply and one hose is connected to one of the outlets. Naturally, both air tracks must be connected to maintain air pressure.

Specifications

- ① When connected to the SF-9214 Precision Air Track (382 holes @ 1 mm (0.038 in) diameter each, total hole area 300 mm² (0.433 in²), the volume and pressure is sufficient to lift a glider with a 200 g load (setting at 50% of full range).
- ② The input current at full speed is 2.2 Amps maximum.
- ③ The sound output is typically 10 - 20 dB above ambient noise. The maximum sound output is low enough to allow normal conversation to be heard when the motor is on.
- ④ The volume of air produced is 1.02 m³/min (36 ft³/min) and the pressure is 867 Pascals (0.0867 N/cm² or 0.122 lbs/in²) or 6.5 mm Hg at *full speed*.

► CAUTION:

For those using SF-9216 Air Supply with equipment other than the PASCO Model SF- 9214 Precision Student Air Track: This air supply is designed for use with equipment for which the total area of air flow is at least 2.6 cm² (0.4 in²). (For air tracks, this area is determined by multiplying the number of air holes on the surface of the track by the surface area per hole).

When used with equipment for which the air flow orifice is less than this value, the rate of air flow is insufficient to cool the air supply, and the supply may overheat and be damaged.

You may remedy this problem either by hooking up the air supply to additional equipment (to meet the 2.6 cm² or 0.4 in² requirement) or by bleeding the air line at some point to increase the area of the unrestricted air flow to an acceptable level.

PCB Schematic

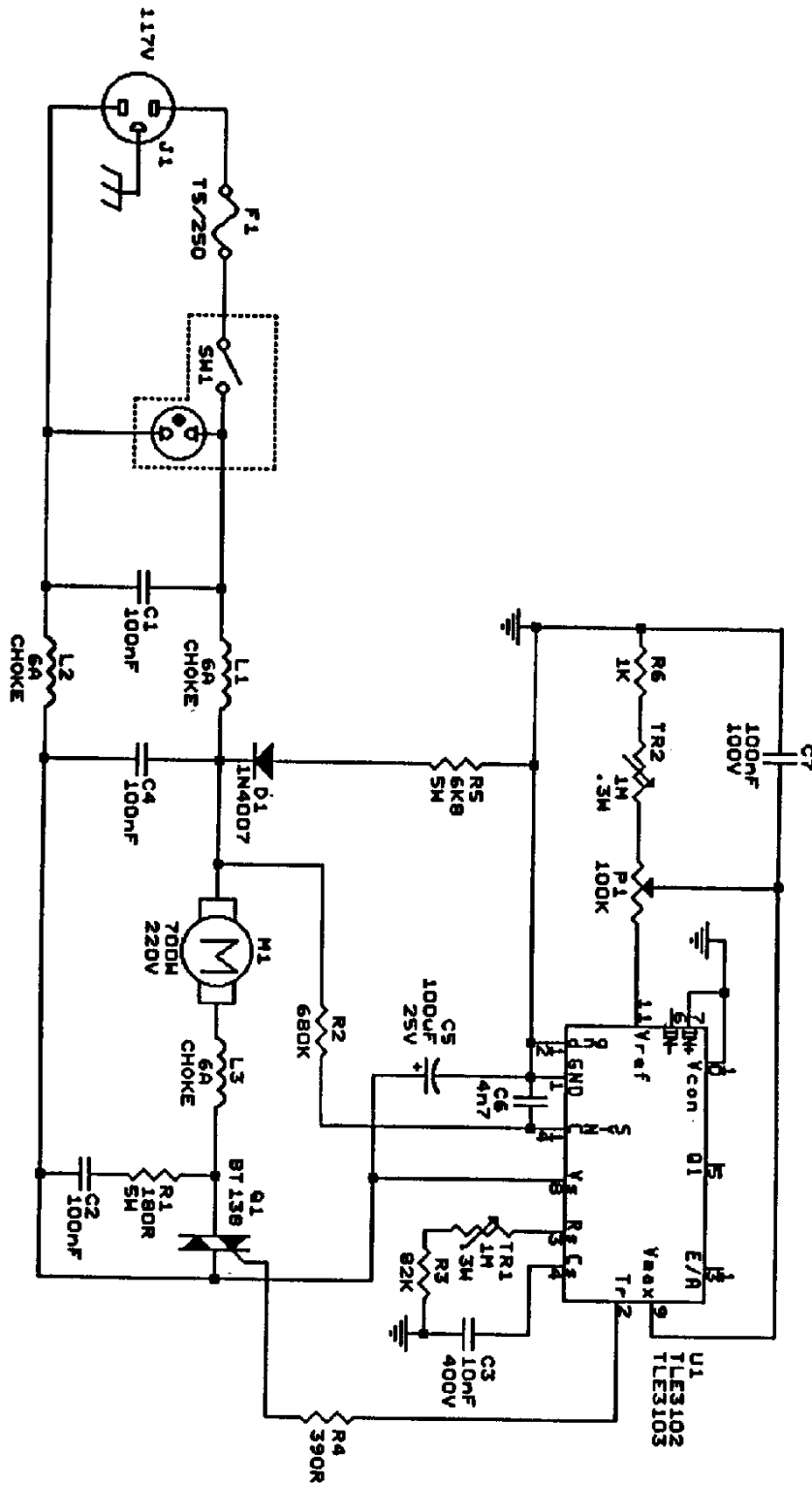

Figure 2

PCB Layout

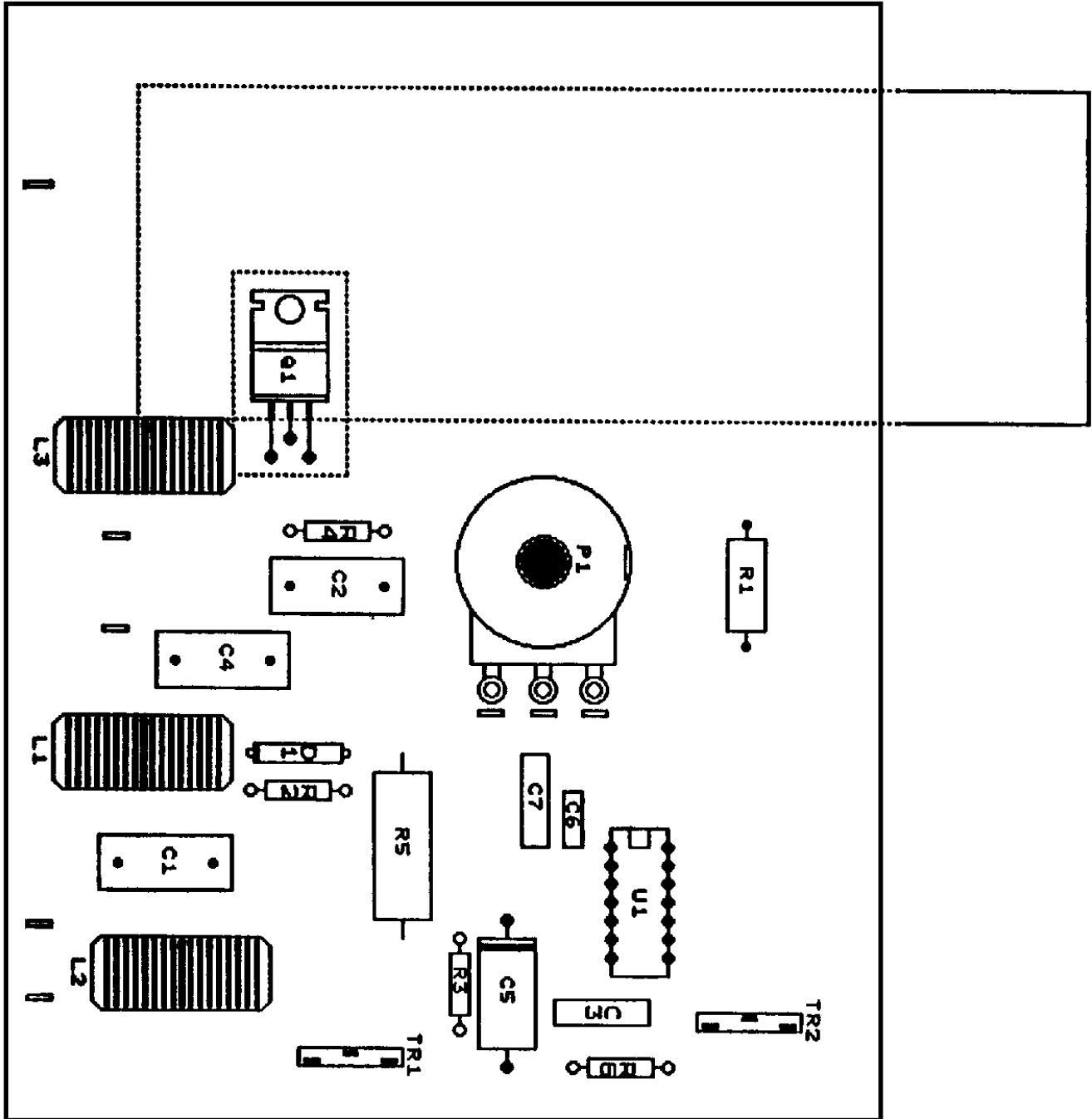

Figure 3

Technical Support

Feed-Back

If you have any comments about this product or this manual please let us know. If you have any suggestions on alternate experiments or find a problem in the manual please tell us. PASCO appreciates any customer feedback. Your input helps us evaluate and improve our product.

To Reach PASCO

For Technical Support call us at 1-800-772-8700 (toll-free within the U.S.) or (916) 786-3800.

email: techsupp@PASCO.com

Tech support fax: (916) 786-3292

Contacting Technical Support

Before you call the PASCO Technical Support staff it would be helpful to prepare the following information:

- If your problem is with the PASCO apparatus, note:
Title and Model number (usually listed on the label).

Approximate age of apparatus.

A detailed description of the problem/sequence of events. (In case you can't call PASCO right away, you won't lose valuable data.)

If possible, have the apparatus within reach when calling. This makes descriptions of individual parts much easier.

- If your problem relates to the instruction manual, note:
Part number and Revision (listed by month and year on the front cover).

Have the manual at hand to discuss your questions.

