

Includes
Teacher's Notes
and
Typical
Experiment Results



Instruction Manual and Experiment Guide for the PASCO scientific Model SE-9638

012-03471E

e/m APPARATUS

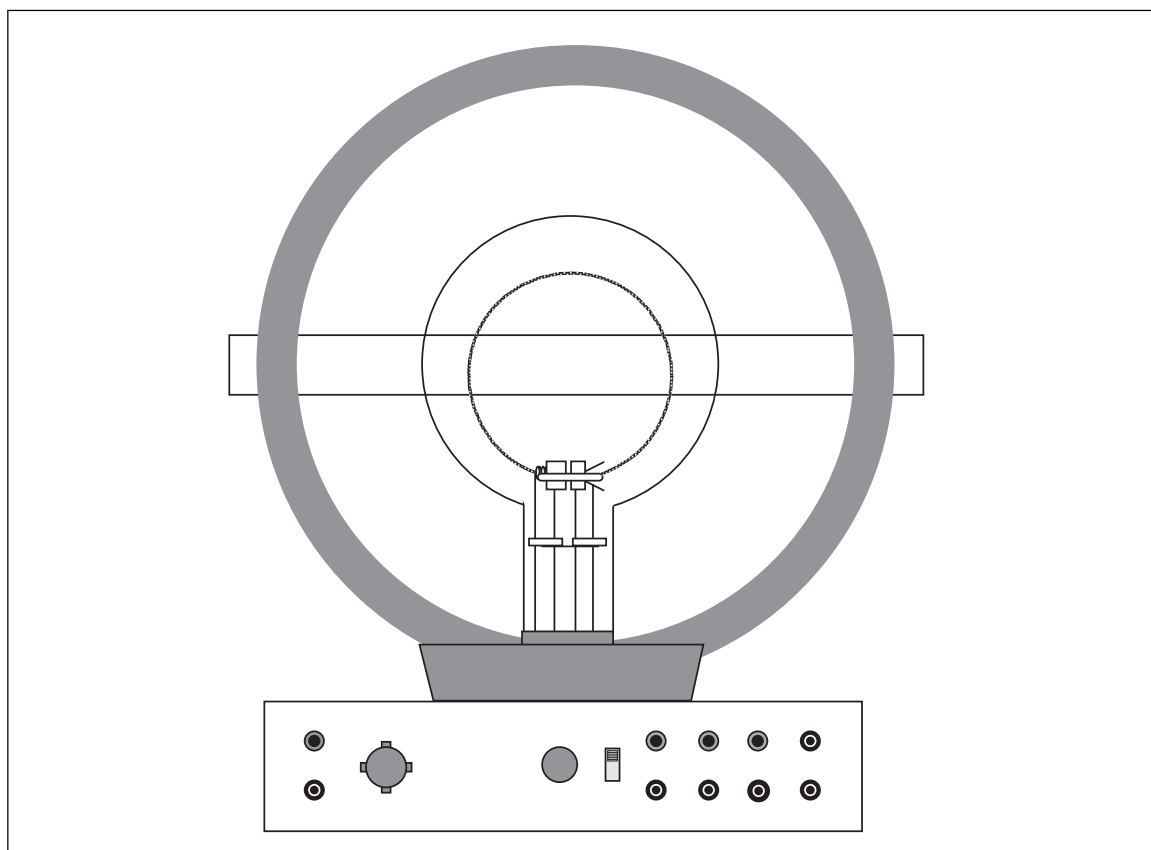

PASCO®

10101 Foothills Blvd. • Roseville, CA 95678-9011 USA

Phone (916) 786-3800 • FAX (916) 786-8905 • web: www.pasco.com

better

ways to

teach science

Discard This Page

Table of Contents

Section	Page
Copyright, Warranty, and Equipment Return	ii
Introduction	1
Equipment	1
Operation	
Measuring e/m	2
Analysis of e/m Measurement	3
Deflections of Electrons in an Electric Field	4
Two Simple Demonstrations	4
Diagram of Connections	5
Improving Experimental Results	6

Copyright and Warranty

Please—Feel free to duplicate this manual subject to the copyright restrictions below.

Copyright Notice

The PASCO scientific Model SE-9638 e/m Apparatus manual is copyrighted and all rights reserved. However, permission is granted to non-profit educational institutions for reproduction of any part of this manual providing the reproductions are used only for their laboratories and are not sold for profit. Reproduction under any other circumstances, without the written consent of PASCO scientific, is prohibited.

Limited Warranty

PASCO scientific warrants this product to be free from defects in materials and workmanship for a period of one year from the date of shipment to the customer. PASCO

will repair or replace, at its option, any part of the product which is deemed to be defective in material or workmanship. This warranty does not cover damage to the product caused by abuse or improper use. Determination of whether a product failure is the result of a manufacturing defect or improper use by the customer shall be made solely by PASCO scientific. Responsibility for the return of equipment for warranty repair belongs to the customer. Equipment must be properly packed to prevent damage and shipped postage or freight prepaid. (Damage caused by improper packing of the equipment for return shipment will not be covered by the warranty.) Shipping costs for returning the equipment, after repair, will be paid by PASCO scientific.

Equipment Return

Should this product have to be returned to PASCO scientific, for whatever reason, notify PASCO scientific by letter or phone BEFORE returning the product. Upon notification, the return authorization and shipping instructions will be promptly issued.

NOTE: NO EQUIPMENT WILL BE ACCEPTED FOR RETURN WITHOUT AN AUTHORIZATION.

When returning equipment for repair, the units must be packed properly. Carriers will not accept responsibility for damage caused by improper packing. To be certain the unit

will not be damaged in shipment, observe the following rules:

1. The carton must be strong enough for the item shipped.
2. Make certain there is at least two inches of packing material between any point on the apparatus and the inside walls of the carton.
3. Make certain that the packing material can not shift in the box, or become compressed, thus letting the instrument come in contact with the edge of the box.

Technical Support

Feed-Back

If you have any comments about this product or this manual please let us know. If you have any suggestions on alternate experiments or find a problem in the manual please tell us. PASCO appreciates any customer feed-back. Your input helps us evaluate and improve our product.

To Reach PASCO

For Technical Support call us at 1-800-772-8700 (toll-free within the U.S.) or (916) 786-3800.

Contacting Technical Support

Before you call the PASCO Technical Support staff it would be helpful to prepare the following information:

- If your problem is computer/software related, note:

Title and Revision Date of software.

Type of Computer (Make, Model, Speed).

Type of external Cables/Peripherals.

- If your problem is with the PASCO apparatus, note:

Title and Model number (usually listed on the label).

Approximate age of apparatus.

A detailed description of the problem/sequence of events. (In case you can't call PASCO right away, you won't lose valuable data.)

If possible, have the apparatus within reach when calling. This makes descriptions of individual parts much easier.

- If your problem relates to the instruction manual, note:

Part number and Revision (listed by month and year on the front cover).

Have the manual at hand to discuss your questions.

Introduction

The PASCO Model SE-9638 e/m Apparatus provides a simple method for measuring e/m , the charge to mass ratio of the electron. The method is similar to that used by J.J. Thomson in 1897. A beam of electrons is accelerated through a known potential, so the velocity of the electrons is known. A pair of Helmholtz coils produces a uniform and measurable magnetic field at right angles to the electron beam. This magnetic field deflects the electron beam in a circular path. By measuring the accelerating potential (V), the current to the Helmholtz coils (I), and the radius of the circular path of the electron beam (r), e/m is easily calculated: $e/m = 2V/B^2r^2$. (The calculations are explained in the operation section of this manual.)

The e/m apparatus also has deflection plates that can be used to demonstrate the effect of an electric field on the electron beam. This can be used as a confirmation of the negative charge of the electron, and also to demonstrate how an oscilloscope works.

A unique feature of the e/m tube is that the socket rotates, allowing the electron beam to be oriented at any angle (from 0-90 degrees) with respect to the magnetic field from the Helmholtz coils. You can therefore rotate the tube and examine the vector nature of the magnetic forces on moving charged particles. Other experiments are also possible with

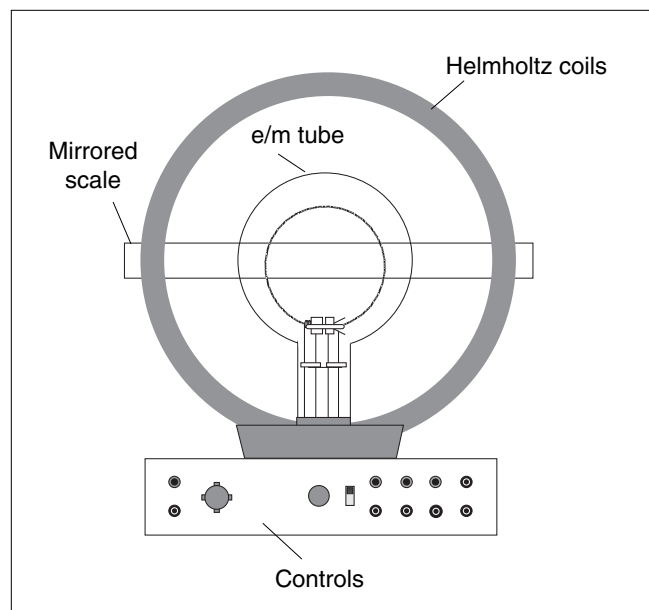

Figure 1 The e/m Apparatus

the e/m tube. For example, you can use a small permanent magnet instead of the Helmholtz coils to investigate the effect of a magnetic field on the electron beam.

Equipment

The e/m Tube The e/m tube (see Figure 2) is filled with helium at a pressure of 10^{-2} mm Hg, and contains an electron gun and deflection plates. The electron beam leaves a visible trail in the tube, because some of the electrons collide with helium atoms, which are excited and then radiate visible light.

The electron gun is shown in Figure 3. The heater heats the cathode, which emits electrons. The electrons are accelerated by a potential applied between the cathode and the anode. The grid is held positive with respect to the cathode and negative with respect to the anode. It helps to focus the electron beam.

CAUTION: The voltage to the heater of the electron gun should NEVER exceed 6.3 volts, unless noted otherwise on tube. Higher voltages will burn out the filament and destroy the e/m tube.

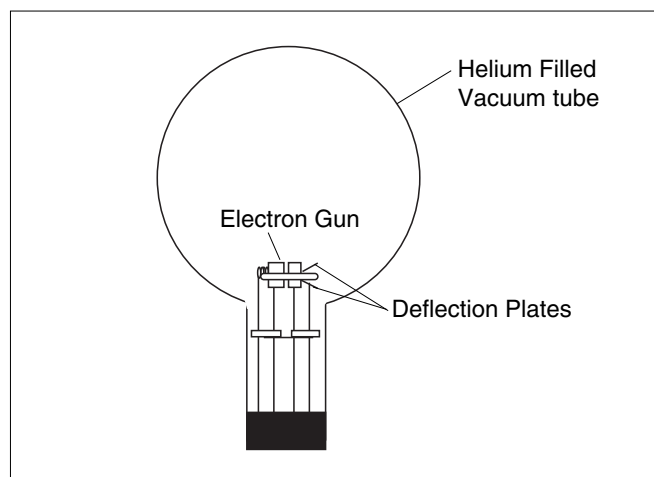

Figure 2 e/m Tube

The Helmholtz Coils—The geometry of Helmholtz coils—the radius of the coils is equal to their separation—provides a highly uniform magnetic field. The Helmholtz coils of the e/m apparatus have a radius and separation of 15 cm. Each coil has 130 turns. The magnetic field (B) produced by the coils is proportional to the current through the coils (I) times 7.80×10^{-4} tesla/ampere [B (tesla) = $(7.80 \times 10^{-4}) I$].

The Controls—The control panel of the e/m apparatus is straightforward. All connections are labeled. The hook-ups and operation are explained in the next section.

Cloth Hood—The hood can be placed over the top of the e/m apparatus so the experiment can be performed in a lighted room.

Mirrored Scale—A mirrored scale is attached to the back of the rear Helmholtz coil. It is illuminated by lights that light automatically when the heater of the electron gun is powered. By lining the electron beam up with its image in the mirrored scale, you can measure the radius of the beam path without parallax error.

Additional Equipment Needed—

Power Supplies:

6-9 VDC @ 3 A (ripple < 1%) for Helmholtz coils
(PASCO Model SF-9584 Low Voltage Power Supply)

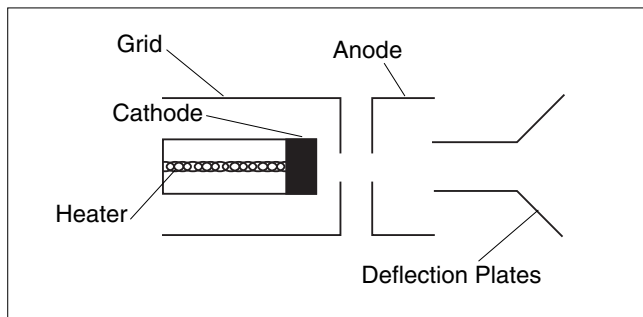

Figure 3 Electron Gun

6.3 VDC or VAC for filament

150-300 VDC accelerating potential (PASCO Model SF-9585 High Voltage Power Supply)

Meters:

Ammeter with 0-2 A range to measure current in Helmholtz coils (such as the PASCO Model SB-9624 Multimeter)

Voltmeter with 0-300 V range to measure accelerating potential (such as the PASCO Model SB-9624 Multimeter)

Operation

Measuring e/m

1. If you will be working in a lighted room, place the hood over the e/m apparatus.
2. Flip the toggle switch up to the e/m MEASURE position.
3. Turn the current adjust knob for the Helmholtz coils to the OFF position.
4. Connect your power supplies and meters to the front panel of the e/m apparatus, as shown in Figure 4.
5. Adjust the power supplies to the following levels:

ELECTRON GUN

Heater:	6.3 (VAC or VDC) or as noted on tube
Electrodes:	150 to 300 VDC
Helmholtz Coils:	6-9 VDC (ripple should be less than 1%)

CAUTION: The voltage to the heater of the electron gun should NEVER exceed 6.3 V, unless noted otherwise on tube. Higher voltages will burn out the filament and destroy the e/m tube.

6. Slowly turn the current adjust knob for the Helmholtz coils clockwise. Watch the ammeter and take care that the current does not exceed 2 A.
7. Wait ten minutes for the cathode to heat up. When it does, you will see the electron beam emerge from the electron gun and it will be curved by the field from the Helmholtz coils. Check that the electron beam is parallel to the Helmholtz coils. If it is not, turn the tube until it is. Don't take it out of its socket. As you rotate the tube, the socket will turn.
8. Carefully read the current to the Helmholtz coils from your ammeter and the accelerating voltage from your voltmeter. Record the values below.

Current to Helmholtz coils = $I =$ _____

Accelerating voltage = $V =$ _____

9. Carefully measure the radius of the electron beam. Look through the tube at the electron beam. To avoid parallax errors, move your head to align the electron beam with the reflection of the beam that you can see

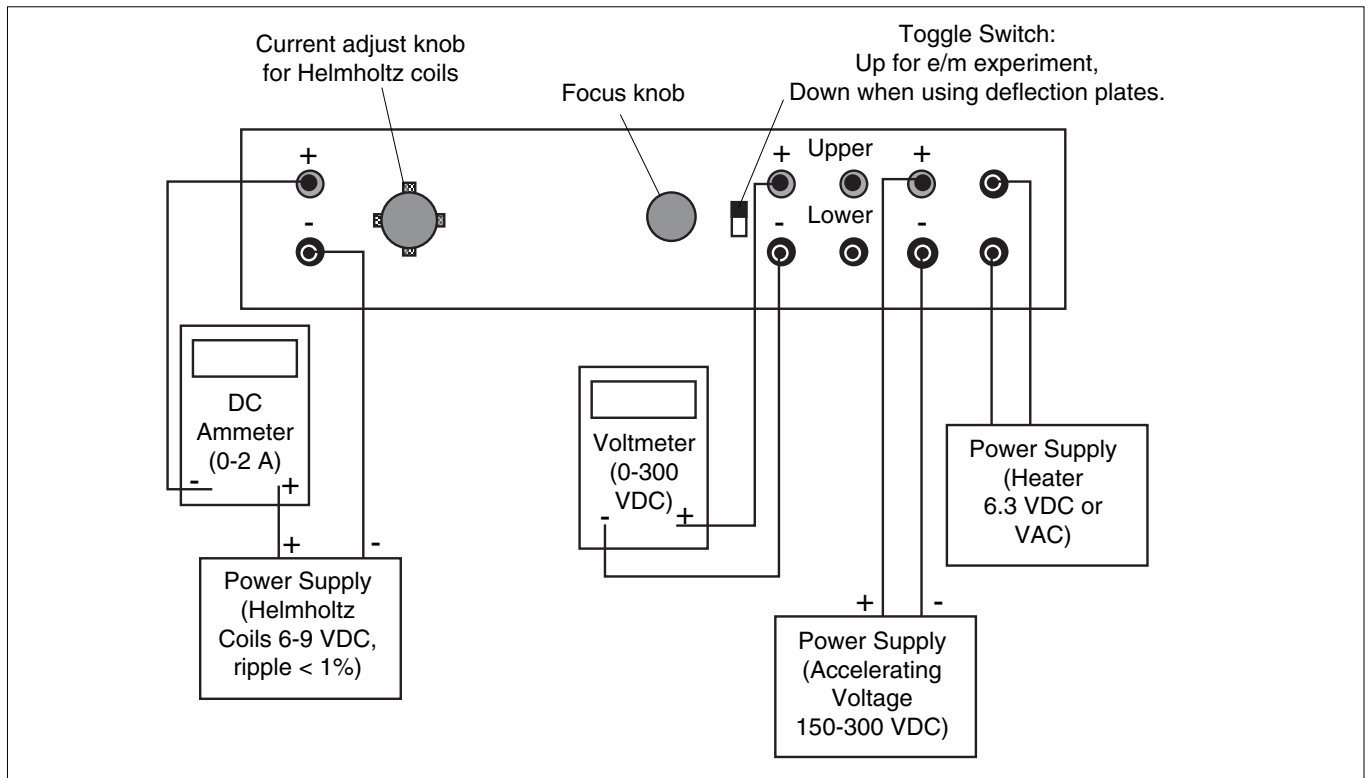

Figure 4 Connections for e/m Experiment

on the mirrored scale. Measure the radius of the beam as you see it on both sides of the scale, then average the results. Record your result below.

Electron Beam Radius = $r =$ _____

Analysis of e/m Measurement

The magnetic force (F_m) acting on a charged particle of charge q moving with velocity v in a magnetic field (B) is given by the equation $F_m = qv \times B$, (where F , v , and B are vectors and \times is a vector cross product). Since the electron beam in this experiment is perpendicular to the magnetic field, the equation can be written in scalar form as:

$$F_m = evB \quad (1)$$

where e is the charge of the electron.

Since the electrons are moving in a circle, they must be experiencing a centripetal force of magnitude

$$F_c = mv^2/r \quad (2)$$

where m is the mass of the electron, v is its velocity, and r is the radius of the circular motion. Since the only force acting on the electrons is that caused by the magnetic field, $F_m = F_c$, so equations 1 and 2 can be combined to give $evB = mv^2/r$ or

$$e/m = v/Br \quad (3)$$

Therefore, in order to determine e/m , it is only necessary to know the velocity of the electrons, the magnetic field produced by the Helmholtz coils, and the radius of the electron beam.

The electrons are accelerated through the accelerating potential V , gaining kinetic energy equal to their charge times the accelerating potential. Therefore $eV = 1/2 mv^2$. The velocity of the electrons is therefore:

$$v = (2eV/m)^{1/2} \quad (4)$$

The magnetic field produced near the axis of a pair of

$$B = \frac{[N\mu_0] I}{(5/4)^{3/2} a} \quad (5)$$

Helmholtz coils is given by the equation:

A derivation for this formula can be found in most introductory texts on electricity and magnetism.

Equations 4 and 5 can be plugged into equation 3 to get a final formula for e/m :

$$e/m = v/Br = \frac{2V (5/4)^{3/2} a^2}{(N\mu_0 I r)^2}$$

where:

V = the accelerating potential

a = the radius of the Helmholtz coils

N = the number of turns on each Helmholtz coil = 130

μ_0 = the permeability constant = $4\pi \times 10^{-7}$

I = the current through the Helmholtz coils

r = the radius of the electron beam path

Deflections of Electrons in an Electric Field

IMPORTANT: Do not leave the beam on for long periods of time in this mode. The beam will ultimately wear through the glass walls of the tube.

You can use the deflection plates to demonstrate how the electron beam is deflected in an electric field.

1. Setup the equipment as described above for measuring e/m except:
 - a. Flip the toggle switch to ELECTRICAL DEFLECT.
 - b. Do not supply current to the Helmholtz coils.
 - c. Connect a 0-50 VDC power supply between the banana plug connectors labeled DEFLECT PLATES (UPPER and LOWER).

2. Apply the 6.3 (VDC or VAC), or voltage noted on tube, to the HEATER and 150-300 VDC to the ELECTRODES of the ELECTRON GUN (the accelerating potential). Wait ten minutes to warm up the cathode.
3. When the electron beam appears, slowly increase the voltage to the deflection plates from 0 V to approximately 50 VDC. Note the deflection of the electron beam. Note that the beam is bent towards the positively charged plate.

Two Simple Demonstrations

1. Instead of using the Helmholtz coils to bend the electron beam, you can use a permanent magnet to show the effect of a magnetic field on the electron beam. Just provide the following power to the e/m apparatus:
 HEATER: 6.3 (VAC or VDC), or voltage noted on tube
 ELECTRON GUN ELECTRODES: 150- 300 VDC
 When the electron beam appears, use your permanent magnet to bend the beam.
2. The socket for the e/m tube is designed so that the tube can be rotated 90 degrees. The tube can therefore be oriented so it is at any angle, from 0-90 degrees, with respect to the magnetic field from the Helmholtz coils. By setting up the equipment as for measuring e/m, you can rotate the tube and study how the beam deflection is affected.

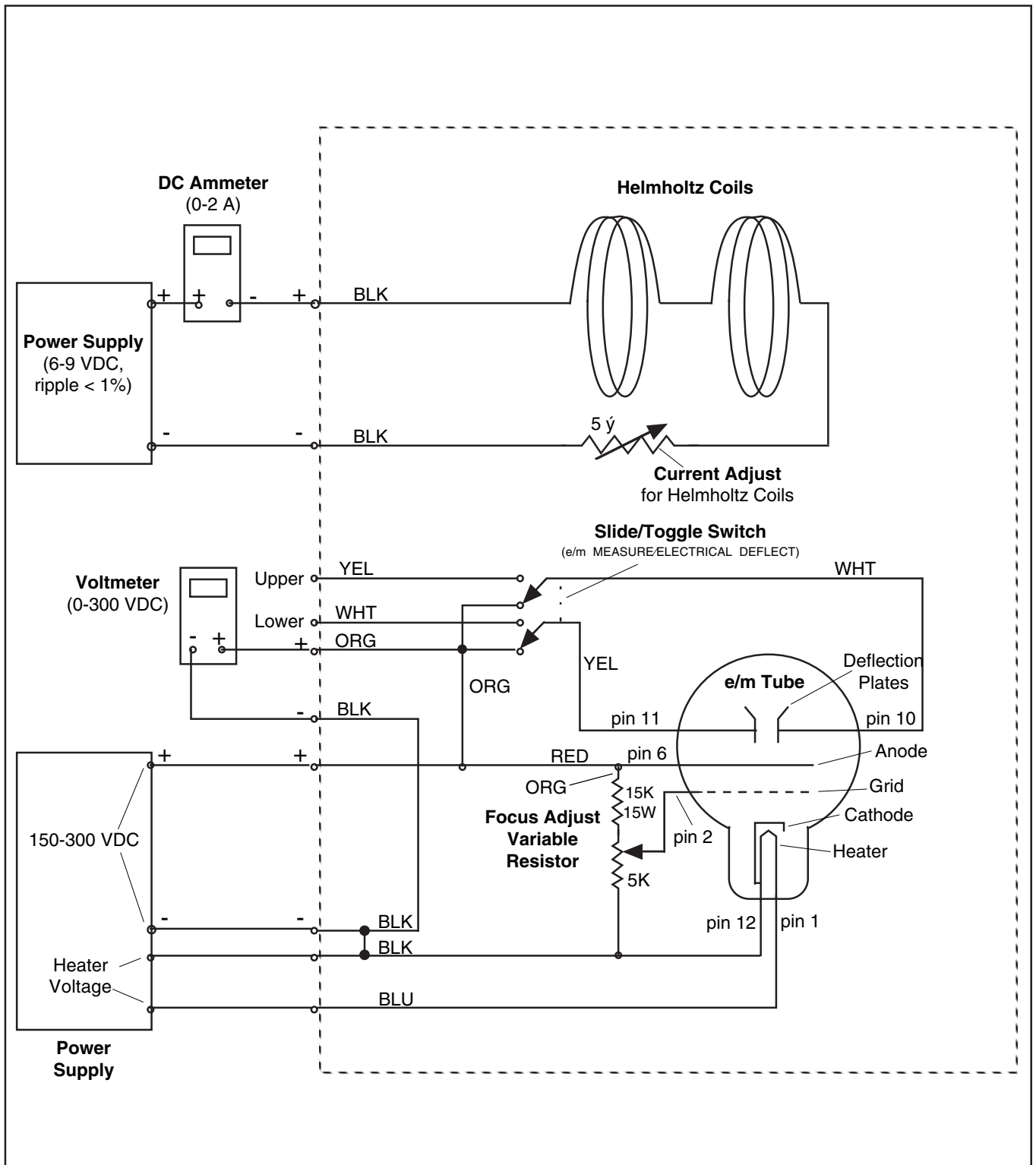

Diagram of Connections for the SE-9638 e/m Apparatus

Improving Experimental Results

Measurement of e/m

Notes

- 1) The greatest source of error in this experiment is the velocity of the electrons. First, the non-uniformity of the accelerating field caused by the hole in the anode causes the velocity of the electrons to be slightly less than their theoretical value. Second, collisions with the helium atoms in the tube further rob the electrons of their velocity. Since the equation for e/m is proportional to $1/r^2$, and r is proportional to v, experimental values for e/m will be greatly affected by these two effects.
- 2) To minimize the error due to this lost electron velocity, measure radius to the outside of the beam path.
- 3) To minimize the relative effect of collisions, keep the accelerating voltage as high as possible. (Above 250V for best results.) Note, however, that if the voltage is too high, the radius measurement will be distorted by the curvature of the glass at the edge of the tube. Our best results were made with radii of less than 5cm.

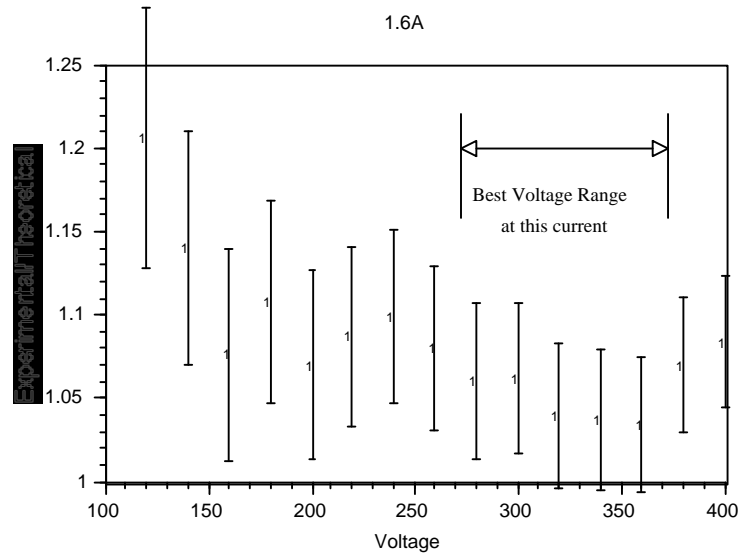

Error bars represent 1mm radius deviation

- 4) Your experimental values will be higher than theoretical, due to the fact that both major sources of error cause the radius to be measured as smaller than it should be.